



AVK SURFACE BOX NORMPOT BRANDKRAAN HD-GG

80/44
006



Fixed height
Surface box for underground hydrants
Standard lid inscription: H water logo



- Normpot Brandkraan HD-GG
 - Oval ductile iron lid
 - Rectangular top surface box



Features

- Lightweight, user-friendly, silent and maintenance free
- 100% recyclable and significantly less use of resources compared to traditional materials
- Manufactured out of high grade recycled materials
- Selected materials for housing and lid ensure easy opening at all times
- Heat resistant to max. 250 °C
- Suitable for low-temperature applications
- Locking clip around the bolt ensuring lid will stay in its place
- D400 load bearing capacity

Optional

- Various colours and lid inscriptions possible
- Available as lockable version making the surface box tamperproof
- Use of a Flexdrain around the hydrant prevents dirt to block the drain pipe, ensuring optimal operation

Standards

- T.V./072/3-E

Accessories

- Top frame hydrant

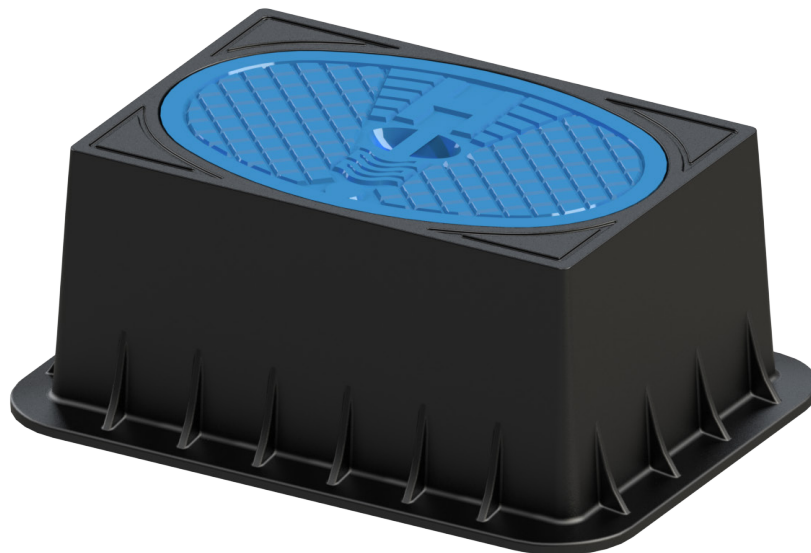

Expect... **AVR**

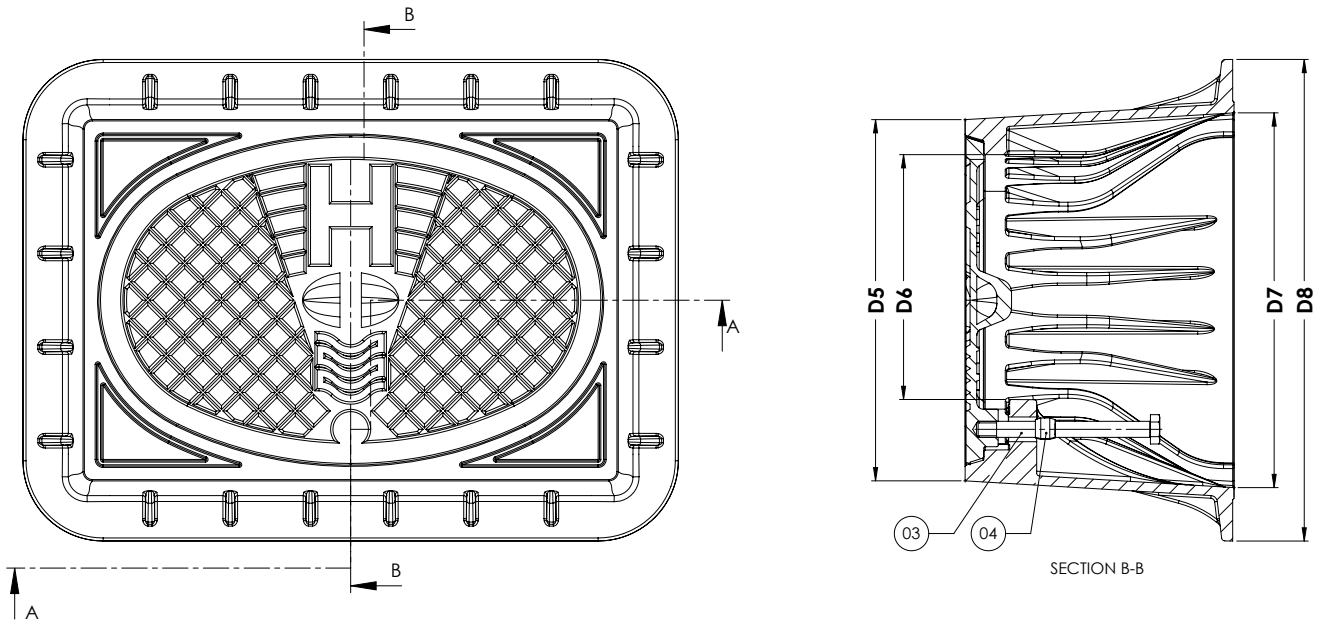

Component list

1. Lid	EN-GJS-500-7
2. Housing	PA+
3. Notched bolt M12x130 hexagon head	A2-70
4. Locking clip	PP

Reference nos. and nominal dimensions

AVK ref. nos.	D1 mm	D2 mm	D3 mm	D4 mm	D5 mm	D6 mm	D7 mm	D8 mm	D9 mm	D10 mm	H mm
80-44-0060006	400	350	410	490	270	182	280	360	374	344	200
	Weight box in kg	Weight lid in kg	Total weight in kg								
	4.8	4.3	9.1								

For other variants different item numbers apply
 Dimensions are subject to tolerances