



## AVK SURFACE BOX H-4055V MD-GG AIR VALVE

80/30  
101



Height adjustable  
Surface box for underground air valves  
Standard lid inscription: AVK AIR VALVE



### Type

- H-4055V MD-GG Air Valve
- Oval cast iron lid
- Oval top surface box



### Features

- Lightweight, user-friendly, silent and maintenance free
- 100% recyclable and significantly less use of resources compared to traditional materials
- Manufactured out of high grade recycled materials
- Ribs in housing ensure optimal fixation in road foundation
- Selected materials for housing and lid ensure easy opening at all times
- Heat resistant to max. 250 °C
- Suitable for low-temperature applications
- Large height range and flexible positioning of top part
- No height adjustment needed after installation, saving time and costs
- Floating top part following road settlement ensuring perfect alignment at all times
- O-ring only to be used for determining final position of top part
- Locking clip around the bolt ensuring lid will stay in its place
- Large clear opening to grant access to air valve below
- Multiple holes in lid allow discharge and admittance of air
  - Discharge: max. 340m<sup>3</sup>/h
  - Admittance: max. 160m<sup>3</sup>/h
- D400 load bearing capacity

### Optional

- Various colours and lid inscriptions possible
- Available as lockable version making the surface box tamperproof
- Use of a Flexdrain around the air valve prevents dirt to block the in-/outlet, ensuring optimal operation

### Standards

- Design derived from DIN 4055
- DVGW VP 310-2

### Accessories

- Support tile II



Top view



23.5 kg  
CO<sub>2</sub> eq.

Expect... **AVR**

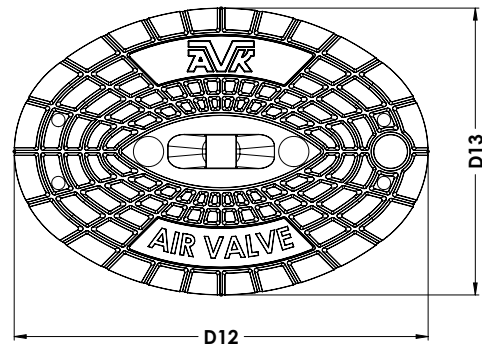
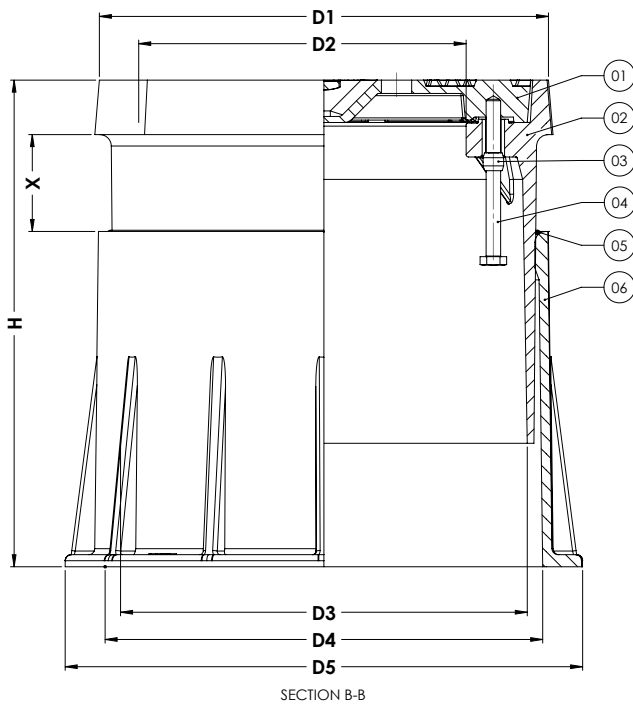
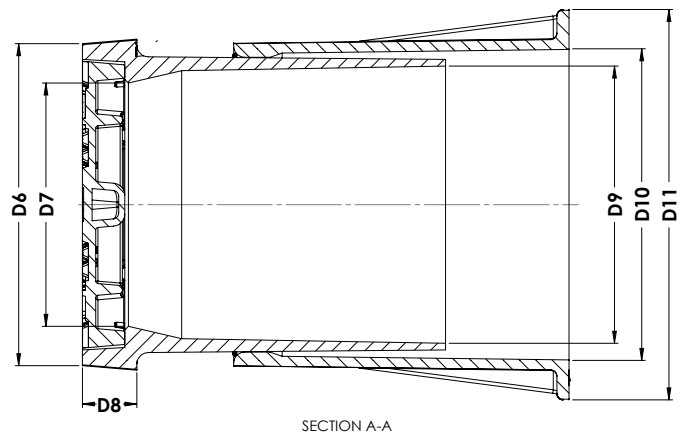
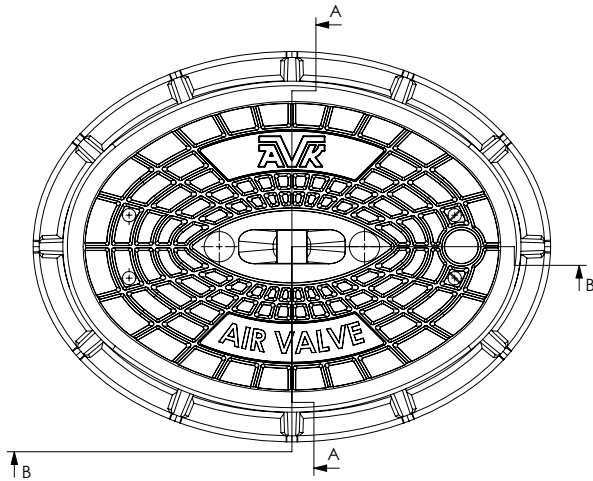

**Component list**

1. Lid	EN-GJL-200
2. Housing top part	PA+
3. Locking clip	PP
4. Notched bolt M12x130 hexagon head	A2-70
5. O-ring	EPDM
6. Housing bottom part	PA+

**Reference nos. and nominal dimensions**

AVK ref. nos.	D1 mm	D2 mm	D3 mm	D4 mm	D5 mm	D6 mm	D7 mm	D8 mm	D9 mm	D10 mm
80-30-1010001	371	271	336	362	428	266	201	44	229	258
	D11 mm	D12 mm	D13 mm	H mm	X mm	Weight box in kg	Weight lid in kg	Total weight in kg		
	323	342	237	400-535	80-215	7.0	7.0	14.0		

For other variants different item numbers apply  
 Dimensions are subject to tolerances