



AVK SURFACE BOX H-4055 MD-KU

80/30
004



Fixed height
Surface box for underground hydrants
Standard lid inscription: AVK HYDRANT



Type

- H-4055 MD-KU
- Oval synthetic lid
- Oval top surface box



Features

- Lightweight, user-friendly, silent and maintenance free
- 100% recyclable and significantly less use of resources compared to traditional materials
- Manufactured out of high grade recycled materials
- Ribs in housing ensure optimal fixation in road foundation
- Selected materials for housing and lid ensure easy opening at all times
- Heat resistant for max. 250 °C
- Suitable for low-temperature applications
- Locking clip around the bolt ensuring lid will stay in its place
- Lid material discourages thieves; no value in stealing
- Synthetic lid enables signal transmission
- C250 load bearing capacity

Optional

- Various colours and lid inscriptions possible
- Available as lockable version making the surface box tamperproof
- Use of a Flexdrain around the hydrant prevents dirt to block the drain pipe, ensuring optimal operation

Standards

- Design derived from DIN 4055
- DVGW VP 310-2

Accessories

- Support tile II



Expect... **AVR**

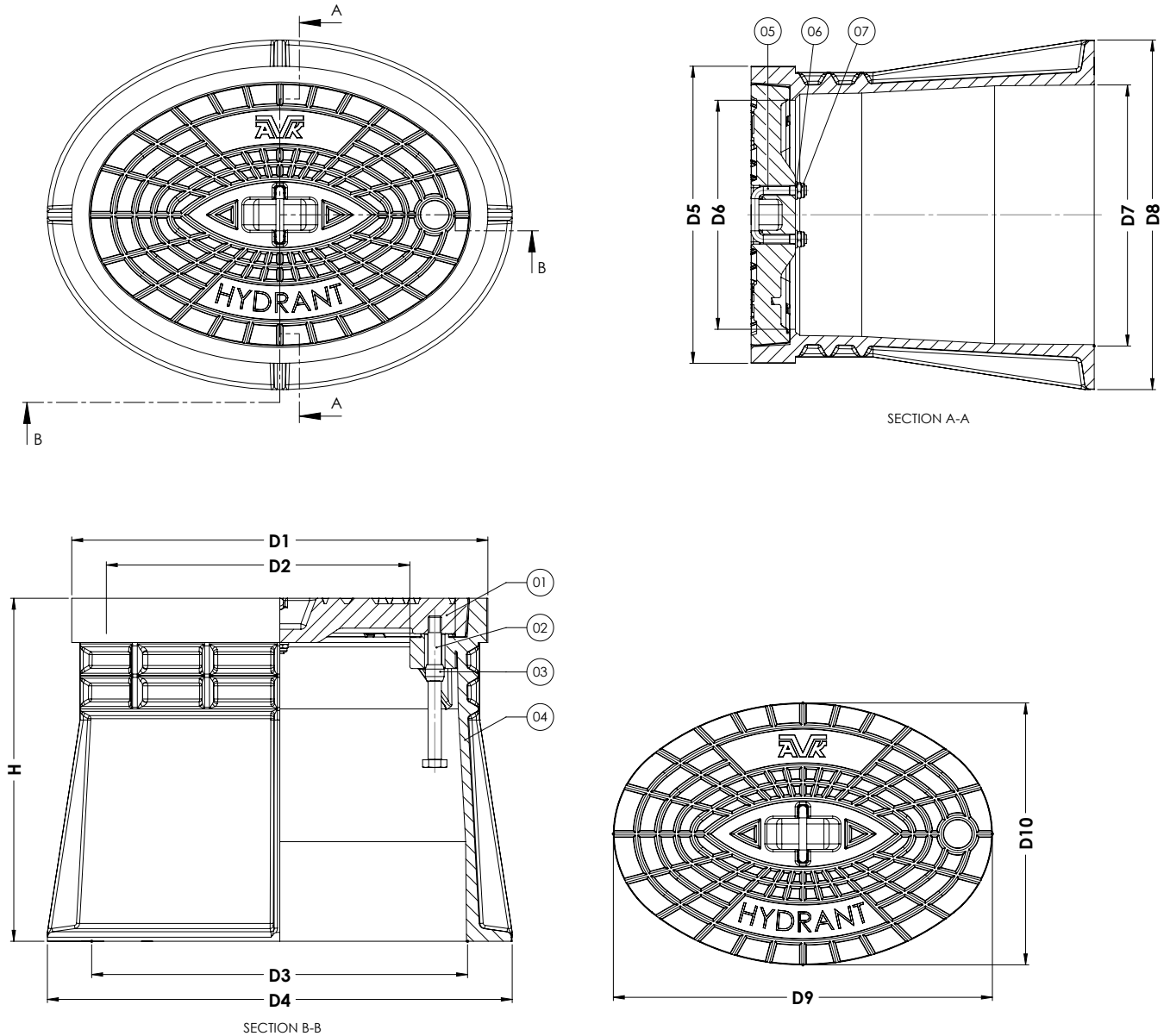

Component list

1. Lid	PP 40%GF
2. Notched bolt M12x130 hexagon head	A2-70
3. Locking clip	PP
4. Housing	PA+
5. Crossbar	A2
6. Washer M8	A2
7. Prevailing torque nut M8	A2

Reference nos. and nominal dimensions

AVK ref. nos.	D1 mm	D2 mm	D3 mm	D4 mm	D5 mm	D6 mm	D7 mm	D8 mm	D9 mm
80-30-0040006	376	274	340	420	268	207	236	316	343
	D10 mm	H mm	Weight box in kg	Weight lid in kg	Total weight in kg				
	237	310	4.0	1.5	5.5				

For other variants different item numbers apply
Dimensions are subject to tolerances