

Final situation

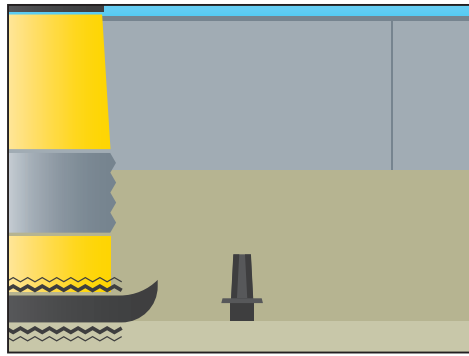

1. Compact the subsoil.

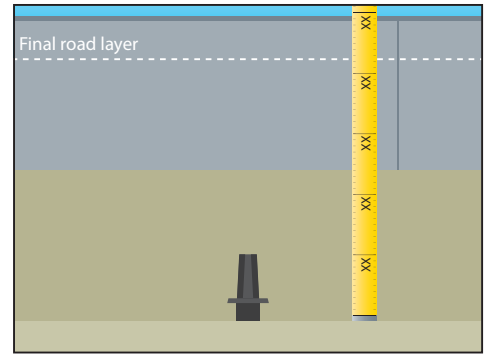

2. Determine the final height of the surface box.

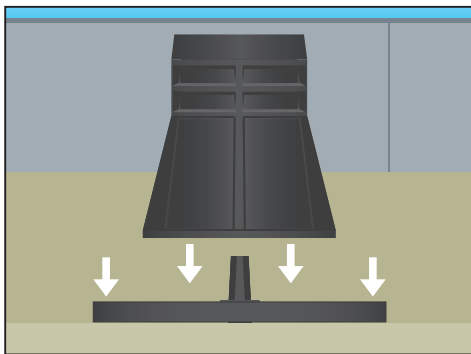

3. Place the support tile (optional) on the subsoil, centre the surface box on the support tile and make sure the top part is in the lowest position.

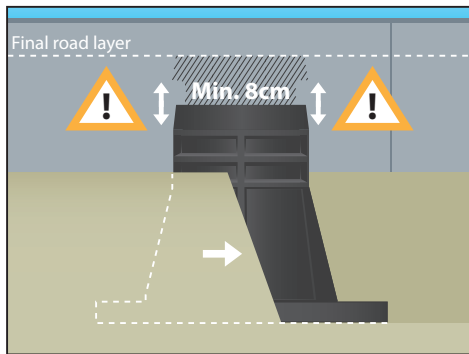

4. Make sure that the space between bottom part and the rim of the top part is at least 8 cm. Surround the surface box with soil/concrete.

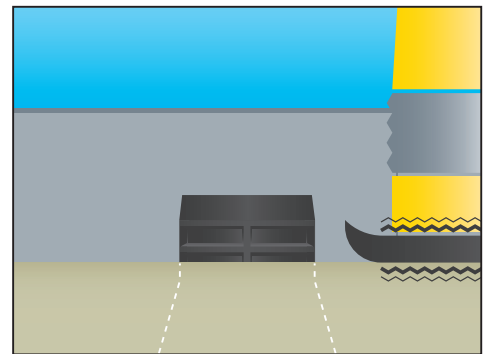

5. Compact the surrounding soil.

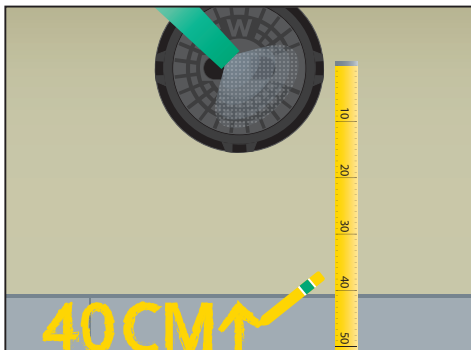

6. Mark the position of the surface box on the curbstone and apply release agent on the lid.

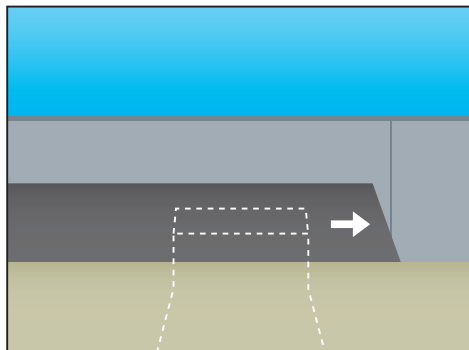

7. Apply the first layer of tarmac. Completely cover the surface box.

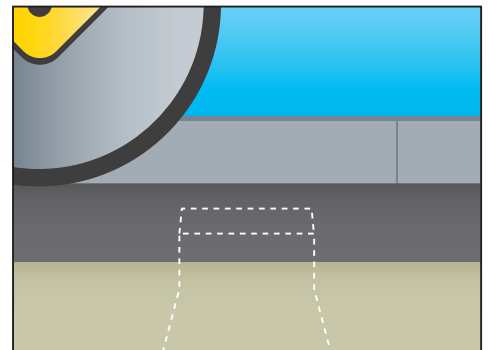

8. Use a roller to compact the tarmac layer.

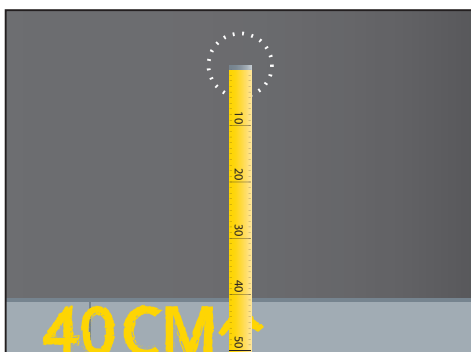

9. Locate the surface box.

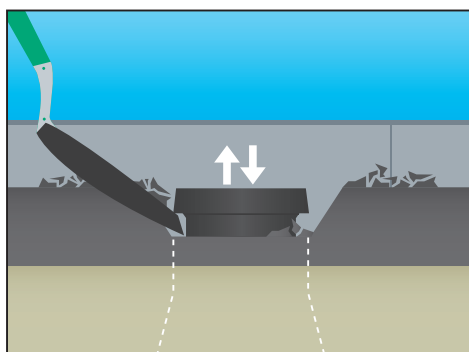

10. Free the top from tarmac and loosen the top part of the surface box. Create a slope of 45°.

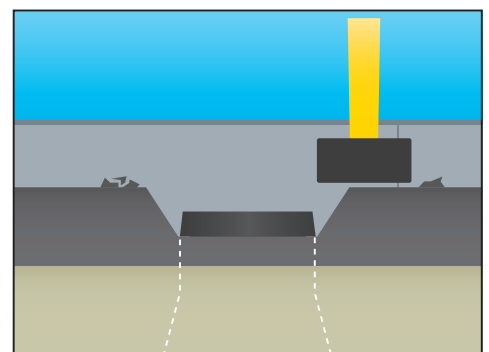

11. Compact the area surrounding the top part.

Check next page for following steps.

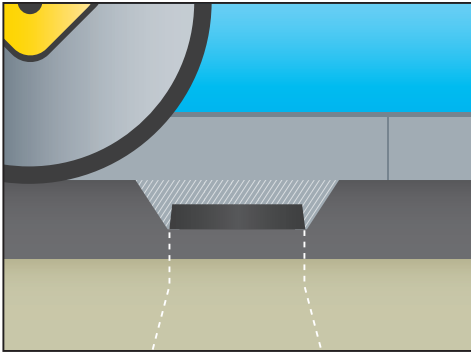

12. Use a roller to compact the first layer of tarmac

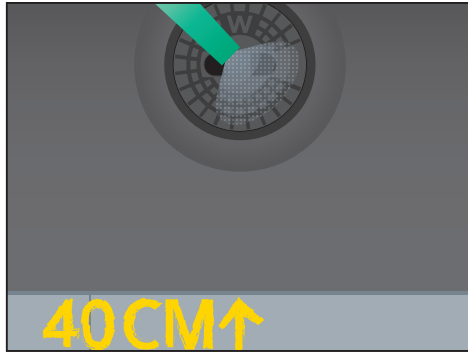

13. Apply release agent on the lid.

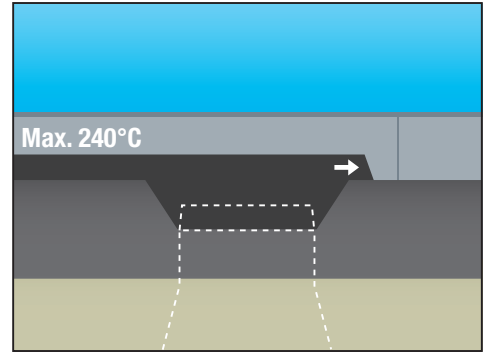

14. Apply the final layer of tarmac.

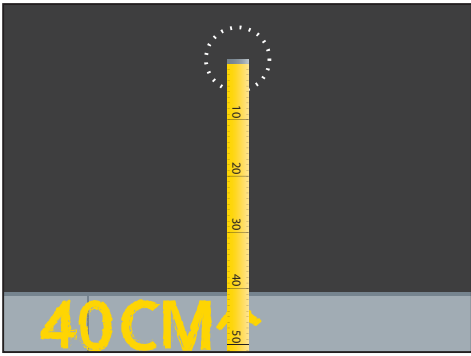

15. Locate the surface box once more.

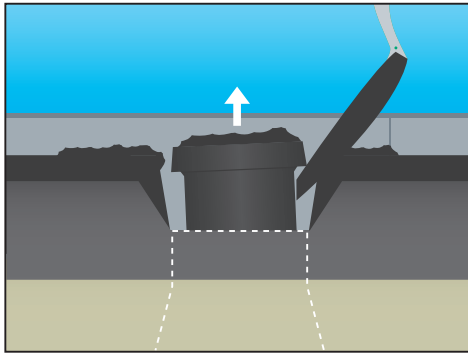

16. Lift the top part till one centimeter above the final layer.

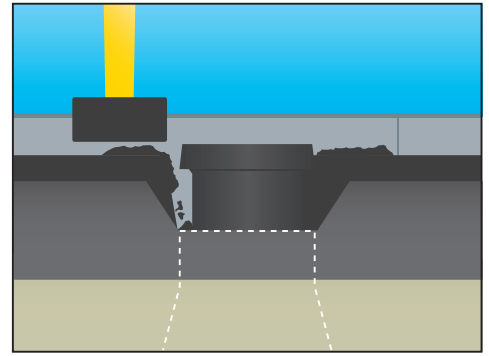

17. Clean the top of the surface box and compact the final layer of tarmac surrounding the top part.

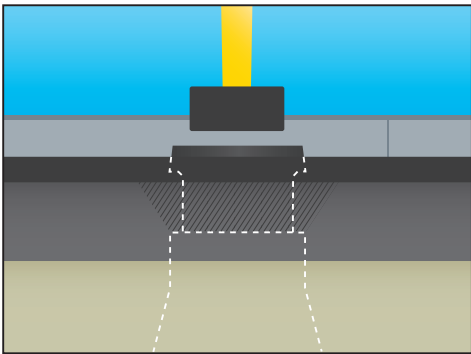

18. Compress the top of the surface box.

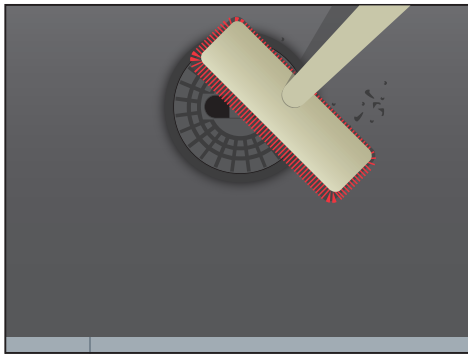

19. Clean the top of the surface box.

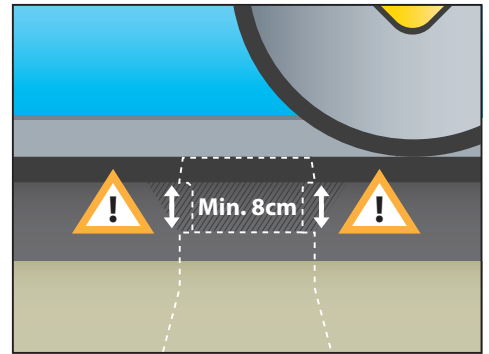

20. Use a roller to compact the final layer.